

**Electronic Ballast for UVC-Lamps with adjustable Lamp Current**

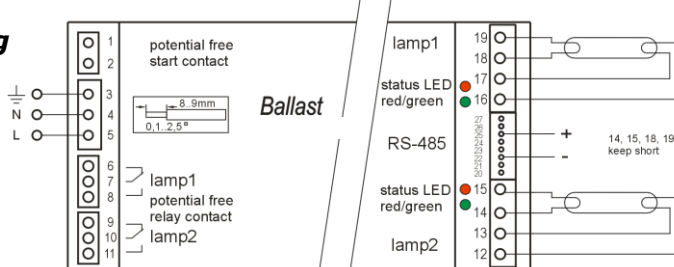

**Wiring**



**Dimensions**

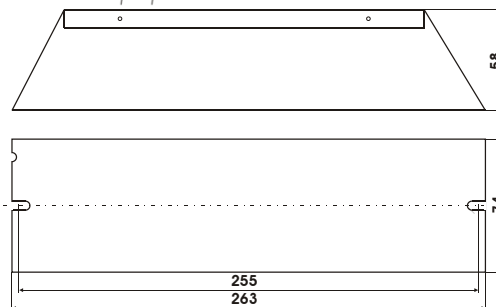

**Features**

- Controller based design (rapid start)
- Lamp current adjustable in steps
- Remote control via RS-485 interface
- 2 separate working lamp channels
- External/internal start alternatively
- Inrush current limiter
- 2 potential free relay contacts

**Technical Data**

Type	LT-UVC 2x (60..100) W 0,35 A .. 0,65 A
Supply	230 V AC $\pm$ 10 % 50/60 Hz
Input power min. / max.	135 W .. 220 W
Output power two lamp application	2x60 W .. 2x100 W
Adjustable range of lamp current	(350 mA / 425 mA / 450 mA / 550 mA / 650 mA) $\pm$ 10 %
Powerfactor	> 0,95
Efficiency	> 0,9
Operating frequency	approx. 28..60 kHz
Inrush current	$\hat{I} < 40$ A to 30 $\mu$ s / $\hat{I} < 30$ A to 300 $\mu$ s
Relay Contact	1 changeover contact
Relay Contact – Maximum switching voltage	5A 250 V AC / 5 A 24 V DC (resistive load)
Relay Contact – Recommended range	$\geq$ 12 V / 10 mA
External start input	10..230 V AC / DC (potential free)
Number of starts	1 start / day recommended
Internal / external start	Adjustable by rotating switch
Independent	1 channel fails, other channel keeps in operation
Standby power dissipation	approx. 1 W
CE-conformity	yes

**Type coding**

R	Rapid start ballast
M	Potential free relay contact
E	External start input
I	– selection lamp current – RS-485 interface

**Adjustment of lamp current**

Adjustment by rotary switch on top of the ballast		Pos. 0..4: internal start (local start) – ballast starts automatically after mains turn on Pos. 5..9: external start (remote start) – ballast starts by external start signal at the start input No warranty for damages caused by incompatible lamps or wrong adjustments!
Lamp typ		On request
Adjustment of lamp current parameters		Must be carried out before voltage application, switching during operation will not be detected

**Adjustment of lamp current**

Switch	Lamp current
0/5	350 mA
1/6	425 mA
2/7	450 mA
3/8	550 mA
4/9	650 mA

**Monitoring**

Mains Control	Switch off at permanent under – or over voltage
Temperature	Switch off at permanent over temperature
Lamp presence	No start if no lamp is connected
Deactivated lamp, rectifier effect	Switch off
Shortage on the lamp line	Switch off
End of life lamp	Switch off

**General indications**

Operation	LED green – trouble free operation
Failure	LED red – failure, no operation
Potential free contact PFK	Relay on – trouble free operation Relay off – failure or ballast does not start (Standby)

**State indications operation/failure**

Ballast status	PFK	LED green	LED red	Description	Cause
No start condition	Off	Permanent blink	Permanent blink	Ballast waits for start	- Under- or over voltage mains - Over temperature - no lamp connected - No HI level at the external start input
Ballast start/ procedure	Off	On	On	Lamp starts	
Ballast works trouble free	On	On	Off	Electronic ballast / lamp – normal mode	
Failure Temperature	Off	Off	1x blinking	Cut off at over temperature Ambient temperature too high Temperature at tc too high	- Wrong installation - No heat dissipation , surface of housing too small
Under voltage mains	Off	Off	2x blinking	Switch off at wrong mains	- Mains voltage under limit
Over voltage mains	Off	Off	3x blinking	Switch off at wrong mains	- Mains voltage over limit
Failure lamp voltage	Off	Off	4x blinking	Switch off Lamp voltage out of tolerance	- Wrong lamp type in use - End of lamp life - Deactivated lamp under operation - Rectifier effect of lamp - Start with deactivated lamp
Failure over current half bridge	Off	Off	5x blinking	Switch off by over current half bridge (abnormal operation)	- Wrong lamp wiring - Shortage on lamp lines - Start without lamps

**Mounting instructions**

Designed for	Installations in switch cabinet
International protection	IP20
Dimension of case	263 x 74 x 57 mm
Installation position	Vertical, mains terminal below
Ambient temperature	ta = 0..40 °C
Temperature at tc-point	tc = 50 °C max. maximum case temperature

**Cabling**

Max. length of lamp cables	< 5 m
Max. capacitance of lamp cables	< 150 pF/m
Screened lamp cables permitted	yes

**Terminal blocks**

Mains Wago 231-303 3 pole Spacing 5,08 mm	Cross section: 0,75–2,5 mm <sup>2</sup> (solid) Cross section: 0,75–1,5 mm <sup>2</sup> (fine-stranded with ferrule)
Lamp Wago 231-304 4 pole Spacing 5,08 mm	Cross section: 0,75–2,5 mm <sup>2</sup> (solid) Cross section: 0,75–1,5 mm <sup>2</sup> (fine-stranded with ferrule)
potential free relay contacts Wago 734-203 3 pole Spacing 3,81 mm	Cross section: 0,2–1,5 mm <sup>2</sup> (solid) Cross section: 0,25–1,0 mm <sup>2</sup> (fine-stranded with ferrule)
external start input Wago 734-202 2 pole Spacing 3,81 mm	Cross section: 0,2–1,5 mm <sup>2</sup> (solid) Cross section: 0,25–1,0 mm <sup>2</sup> (fine-stranded with ferrule)

**Communication parameters**

Baud rate	9600
Date bit	8
Stop bit	1
Parity	none

**Wiring RS-485 interface**

Maximum number of slaves	32
Bus termination	120 Ohm resistor at both ends of the network

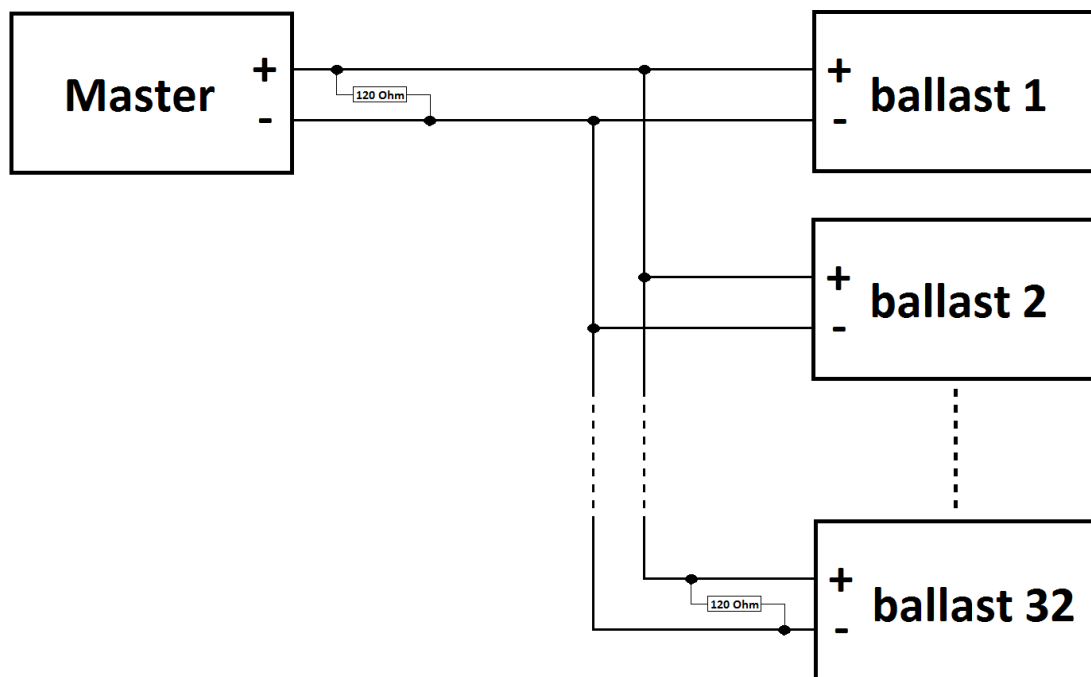

**Addressing**

Ballast-address	DIP-switch				
	1	2	3	4	5
1	0	0	0	0	0
2	1	0	0	0	0
3	0	1	0	0	0
4	1	1	0	0	0
5	0	0	1	0	0
6	1	0	1	0	0
7	0	1	1	0	0
8	1	1	1	0	0
9	0	0	0	1	0
10	1	0	0	1	0
11	0	1	0	1	0
12	1	1	0	1	0
13	0	0	1	1	0
14	1	0	1	1	0
15	0	1	1	1	0
16	1	1	1	1	0
17	0	0	0	0	1
18	1	0	0	0	1
19	0	1	0	0	1
20	1	1	0	0	1
21	0	0	1	0	1
22	1	0	1	0	1
23	0	1	1	0	1
24	1	1	1	0	1
25	0	0	0	1	1
26	1	0	0	1	1
27	0	1	0	1	1
28	1	1	0	1	1
29	0	0	1	1	1
30	1	0	1	1	1
31	0	1	1	1	1
32	1	1	1	1	1

**Function code**

Function code	MODBUS function	Register
01	Read Boolean variables	1 - 3
03	Read Numeric variables	4001 - 4017
05	Set Single Boolean variables	1 - 3

**Data**

Register	Address	Name	Description	Data type
1	0x00	Power	0 = ON (ballast works) 1 = OFF (ballast in standby)	Boolean
2	0x01	RESET lamp 1 Operating time counter/Start counter	0 = Operating 1 = Set counter to 0	Boolean
3	0x02	RESET lamp 2 Operating time counter/Start counter	0 = Operating 1 = Set counter to 0	Boolean
4001	0x00	Ballast address	Displays the set ballast address (1 - 32)	Word
4002	0x01	Ballast type	1 = LT-UVC2x(30..80)W-R/M/E/I 0,35..0,8 A 2 = LT-UVC2x(30..80)W-R/M/E/I 0,8..1,5 A 3 = LT-UVC2x(60..100)W-R/M/E/I 0,35..0,65 A 4 = LT-UVC2x(80..125)W-R/M/E/I 0,8..1,5 A 5 = LT-UVC2x(100..200)W-C/M/E/I 1,2..2,1 A	Word
4003	0x02	Switch position	Displays the adjustment of lamp current (0 - 9)	Word

4004	0x03	State lamp 1	1 = Ballast start 2 = Lamp preheating 3 = Ballast works 4 = Ballast waits for start 5 = Reserved 6 = Failure – Temperature 7 = Failure – Under voltage mains 8 = Failure – Over voltage mains 9 = Failure – Lamp voltage 10 = Failure – Over current 11 = Failure – Over current Preheating	Word
4005	0x04	State lamp 2	1 = Ballast start 2 = Lamp preheating 3 = Ballast works 4 = Ballast waits for start 5 = Reserved 6 = Failure – Temperature 7 = Failure – Under voltage mains 8 = Failure – Over voltage mains 9 = Failure – Lamp voltage 10 = Failure – Over current 11 = Failure – Over current Preheating	Word
4006	0x05	Operating time counter lamp 1 - Minute	Displays the operating time in minutes (0 - 60 min.) - counter only works in state 3 -	Word
4007	0x06	Operating time counter lamp 1 - Hour	Displays the operating time in hours (0 - 65535 h) - counter only works in state 3 -	Word
4008	0x07	Operating time counter lamp 2 - Minute	Displays the operating time in minutes (0 - 60 min.) - counter only works in state 3 -	Word
4009	0x08	Operating time counter lamp 2 - Hour	Displays the operating time in hours (0 - 65535 h) - counter only works in state 3 -	Word
4010	0x09	Start counter lamp1	Displays the number of lamp starts (0 - 65535)	Word
4011	0x0A	Start counter lamp2	Displays the number of lamp starts (0 - 65535)	Word
4012	0x0B	Ballast temperature	Displays the temperature of the ballast in °C (ballast switch off at approx. 80 °C ) - does not reflect the temperature at the case( $t_{c-point}$ ) -	Word
4013	0x0C	Main voltage	1 = Mains voltage under limit ( $U_{Netz} < 187 V$ ) 2 = Typical tolerance ( $187 V < U_{Netz} < 253 V$ ) 3 = Mains voltage over limit ( $U_{Netz} > 253 V$ )	Word
4014	0x0D	Lamp voltage lamp 1	Displays the lamp voltage in V ( $\pm 10\%$ )	Word
4014	0x0D	Lamp voltage lamp 2	Displays the lamp voltage in V ( $\pm 10\%$ )	Word
4014	0x0D	Lamp current lamp 1	Displays the lamp current in mA ( $\pm 10\%$ )	Word
4014	0x0D	Lamp current lamp 2	Displays the lamp current in mA ( $\pm 10\%$ )	Word

**Checksum**

Calculation algorithm	CRC 16
Generator polynomial	0x8005
CRC-start value	0xFFFF

**Error control**

Error code	Description
0x01	Using an unsupported function code
0x02	Using an invalid memory address